

Reflective Edge Light Marker (RELM)



The Reflective Edge Light Marker (RELM) has been designed to provide superior visibility, day or night, to all types of runway and taxiway lights. The very bright, full length, Retro-Reflective fluorescent colour allows extreme daytime visibility and assure reflectiveness quality in night time operation will enable the user clear visibility of each location desired at extreme distances.

The Reflective Edge Light Marker construction consists of a high grade polyurethane tube, spring loaded at the base and mounted to a rust resistant heavy duty bracket adapted to any fixture type. The polyurethane tube is covered with a retro-reflective fluorescent sleeve (orange, blue, green or yellow) which is fastened by means of a through ty to prevent even minimal slippage due to extreme wind velocities or jet blasts. Specifically designed to be used to aid in snow clearing operations or general maintenance duties.

FEATURES & BENEFITS

INCREASE SAFETY

The Reflective Edge Light Marker provides a highly reflective, surface area specifically designed for runways, taxiways and helipads where edge lights need to be visible.

DECREASE COSTS

With a low cost up front capital investment, exponential savings are realized over time through the elimination of accidental snow plow or vehicle damage.

WEATHER PROTECTION

The Reflective Edge Light Marker delivers reliable operations, manufactured out of high-grade polyethylene & resistant to corrosion.

SPECIFICATIONS

OPERATION

Configuration	Reflective Edge Light Marker
Visible Distance	Visibility on average of .5 Km day or night

MECHANICAL

Color	Orange, Blue, Green or Yellow
Body	High Grade Polyurethane UV Stabilized
Reflective Strip	Removable Reflective Sleeve - Outer Sheath
Mounting Accesories	Stake / Polyethylene base / Galvanized steel floor flange
Dimensions	Height 18" / 24" / 36"
Frangible	Body and mounting accesories

ENVIRONMENTAL

Weather Proof	Ice, snow and rain (remains flexible through high/low temperature extremes)
Wind Load	200 kph (125 mph)

WARRANTY

Warranty	1 year
-----------------	--------

FASTENING ASSEMBLY "A"

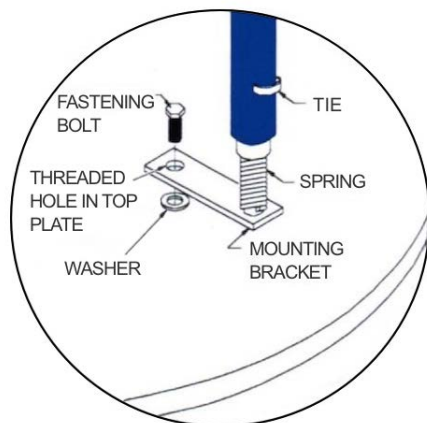

FASTENING ASSEMBLY "B"

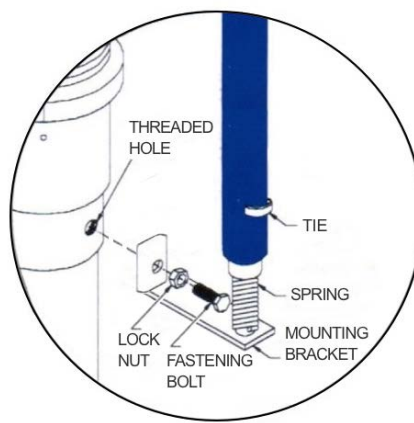

FASTENING ASSEMBLY "C"

